



INSTALLATION INSTRUCTIONS

Accessory
ENGINE BLOCK HEATER
P/N 08T44-SNA-101

Application
2015 RDX

Publications No.
BII 51214
Issue Date
MARCH 2014

PARTS LIST

Engine block heater

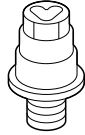

Aluminum washer



Heater harness

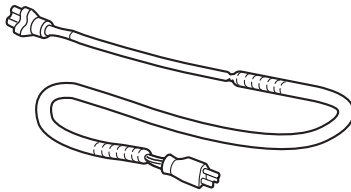

Protective cap

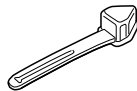

12 Black wire ties

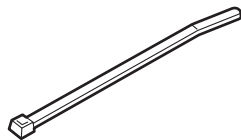

7 Wire ties with clips
(6 not used)

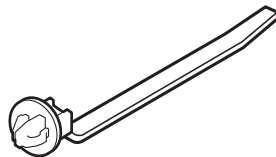

5 Wire ties (Not black)
(2 not used)

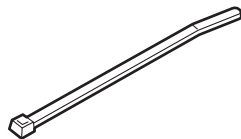

TOOLS AND SUPPLIES REQUIRED

Ratchet

10 mm, 19 mm, and 24 mm Sockets

10 mm Open end wrench

Torque wrench

Diagonal cutters

Heavy gloves

Drain pan

Tape measure

White marker

Coolant (Acura long life Antifreeze/Coolant Type 2)

Fender cover

Phillips screwdriver

Masking tape

Blanket

Drill

3 mm and 7 mm Drill bits

File

Eye protection (face shield, safety goggles, etc.)

Ruler

Pushpin

5 mm Hex wrench

The following tool is available through the Honda Tool and Equipment Program. On the iN, click on: Service > Service Bay > Tool and Equipment Program, then enter the number under "Search." Or, call 888-424-6857.

Trim Tool Set (T/N SOJATP2014)

Illustration of the Engine Block Heater in the Vehicle

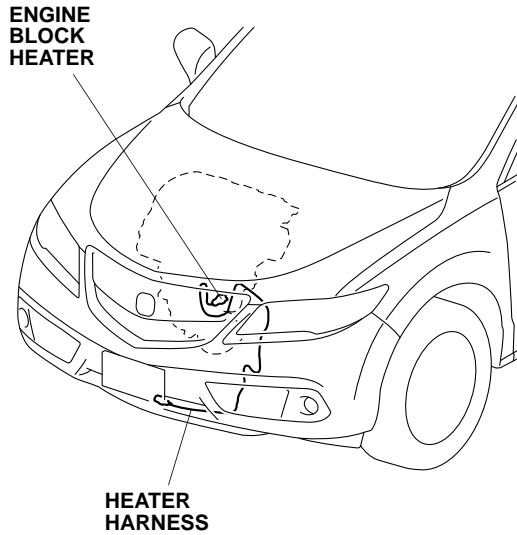

INSTALLATION

NOTE:

- Always use, Acura Long Life Antifreeze/Coolant Type 2. Using a non-Acura coolant can result in corrosion, causing the cooling system to malfunction or fail.
- To avoid burning out the element, do not operate the engine block heater until it is installed in the vehicle and you have added coolant.

Client Information: The information in this installation instruction is intended for use only by skilled technicians who have the proper tools, equipment, and training to correctly and safely add equipment to your vehicle. These procedures should not be attempted by “do-it-yourselfers.”

1. Disconnect the negative cable from the battery.
2. Allow the engine and all cooling system components to cool down.

3. Place a clean drain pan under the radiator drain plug, then remove the drain plug from the bottom of the radiator to drain the coolant. Remove the radiator cap to increase the flow.

NOTICE: Radiator coolant will damage the paint. Quickly rinse any spilled coolant from the paint finish.

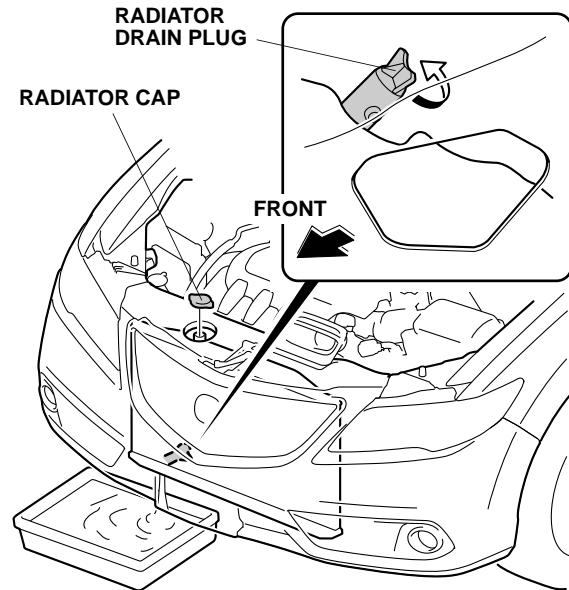

4. After the coolant drains, reinstall the radiator cap to prevent dirt and contamination from entering the radiator.

5. Apply masking tape to the front bumper, left headlight and left front fender as shown.

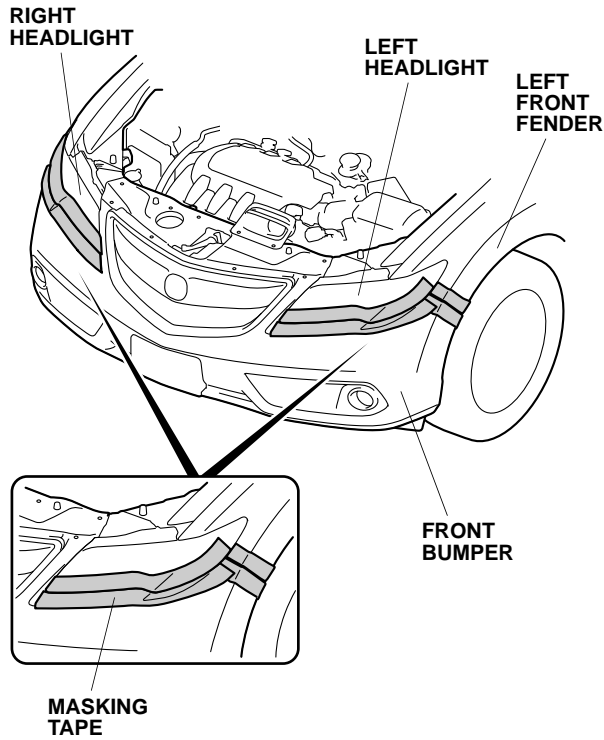

6. Repeat step 5 to apply masking tape to the right side of the vehicle.
7. Remove the front grille cover and air duct (ten clips).

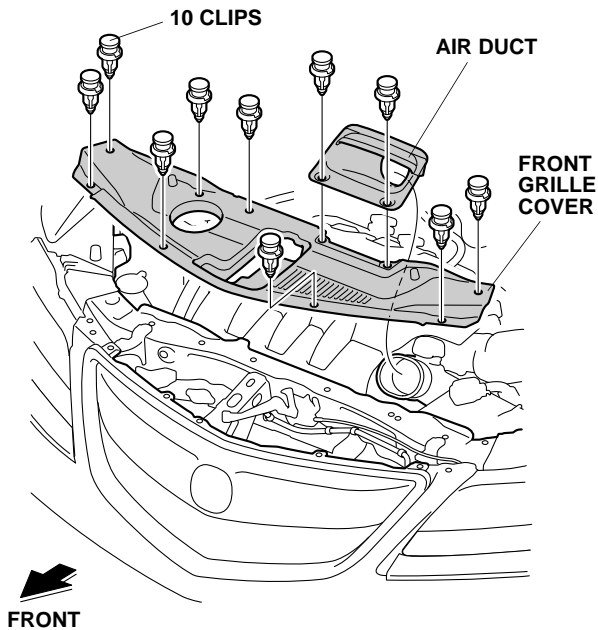

8. Remove the front bumper.
 - Remove the two self-tapping screws, two hex bolts, ten clips, and two long clips.

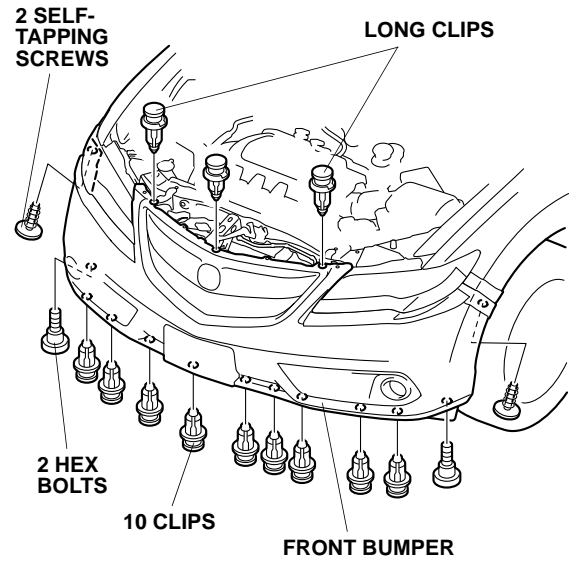

- Release the three retaining tabs on each side.

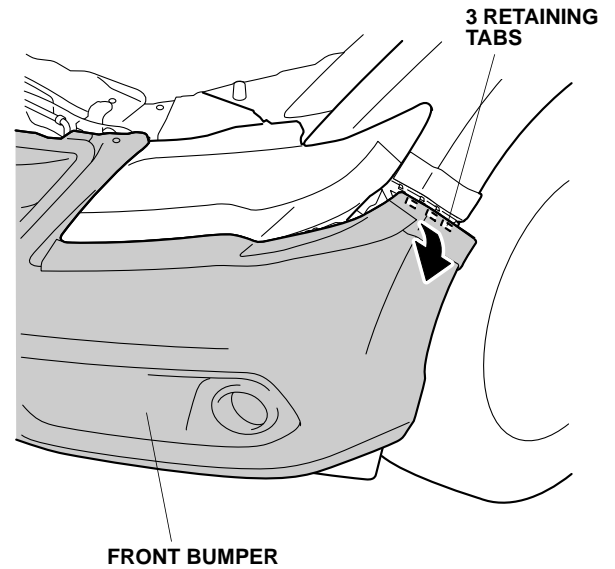

- Release the six retaining tabs on each side.

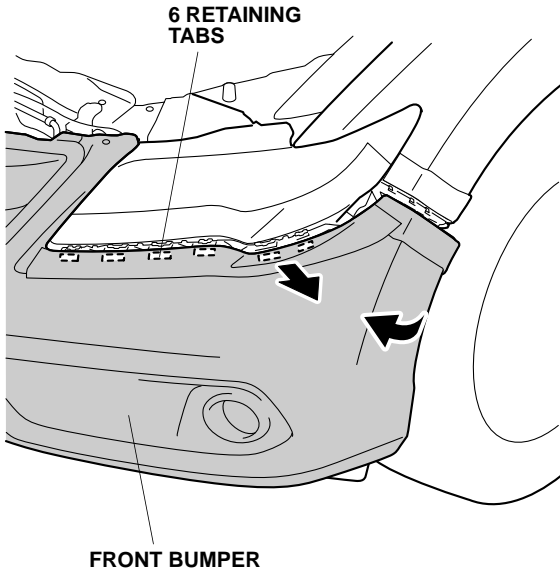

- With the help of an assistant, remove the front bumper.
- Place the front bumper on a blanket.

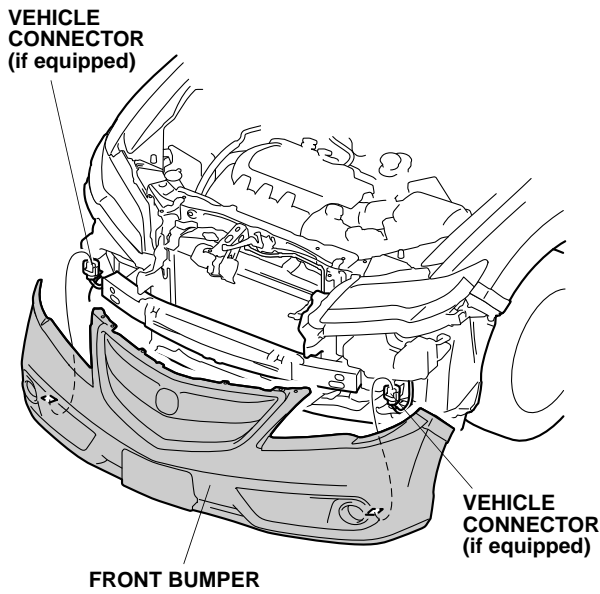

9. Open the positive cable cover, and disconnect the positive (+) battery cable from the battery.

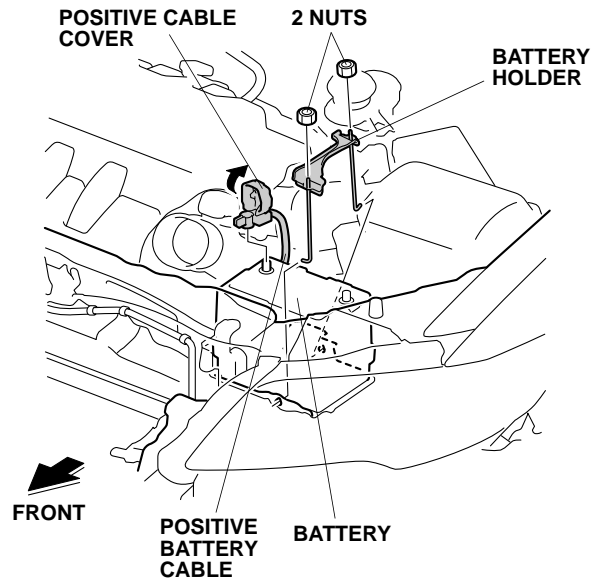

10. Remove the battery holder (two nuts).
11. Remove the battery cover, battery, and battery tray.

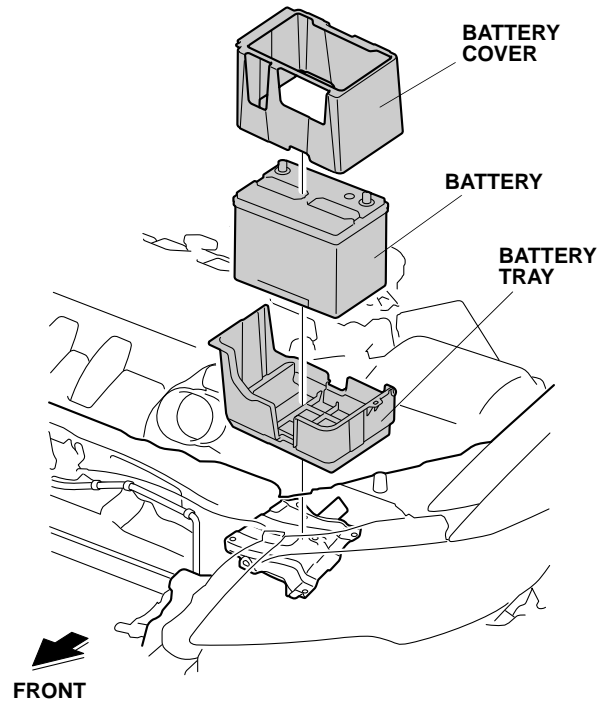

12. Using a pushpin, pierce the side duct and engine under cover at the measurements shown.

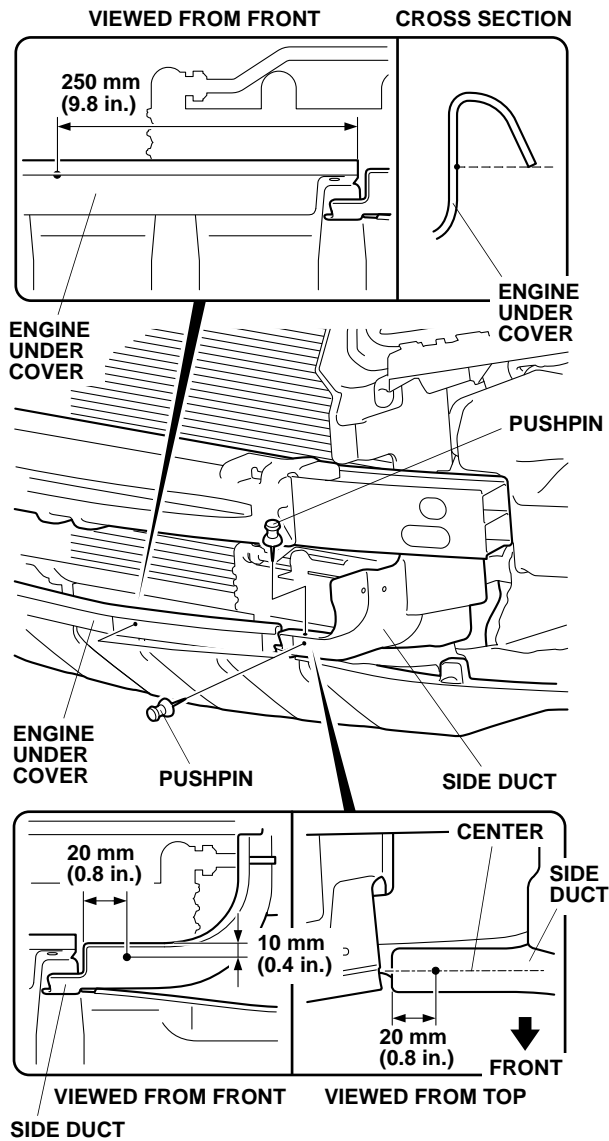

13. While wearing eye protection, drill the three pierced marks on the side duct and engine under cover with a 3 mm drill bit, then enlarge the three holes with a 7 mm drill bit. Remove any burrs. Wrap tape around each drill bit 7 mm away from the tip or use a drill stop.

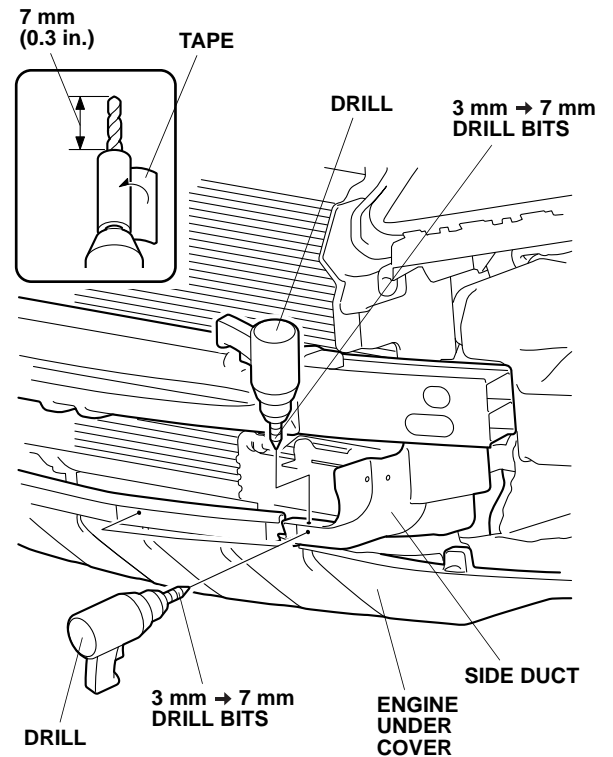

14. Using the measurements shown, install one wire tie with clip to the heater harness.

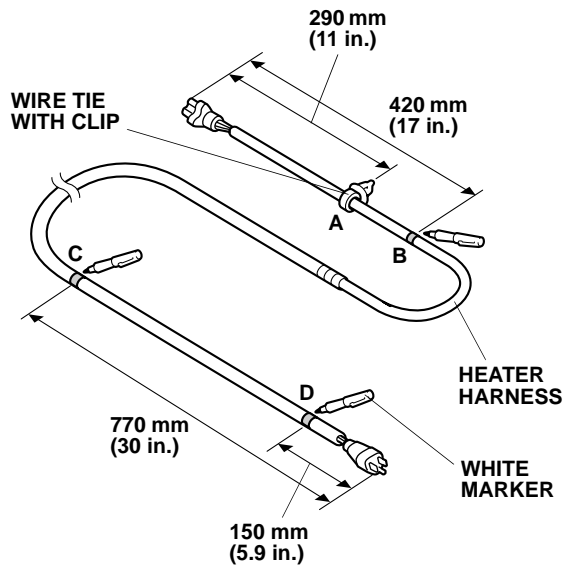

15. Using a white marker, mark the heater harness at the three measurements shown.

16. Locate and remove the drain bolt and washer. Coolant remaining in the engine jackets will flow out of the bolt hole when the bolt is removed. (Retain the bolt, it will be used if the engine block heater is removed.)

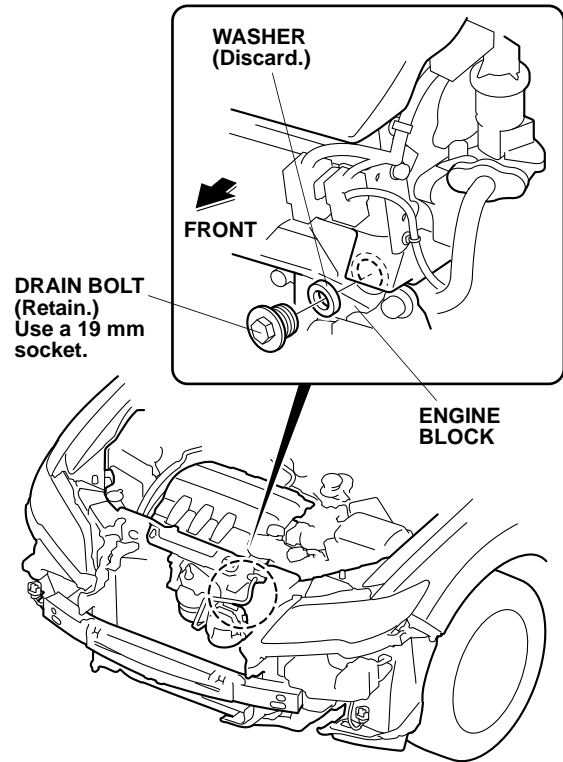

17. Install the engine block heater and aluminum washer into the engine block using a 24 mm socket and a torque wrench. Torque the engine block heater to 75~85 N·m (55~63 lbf·ft).

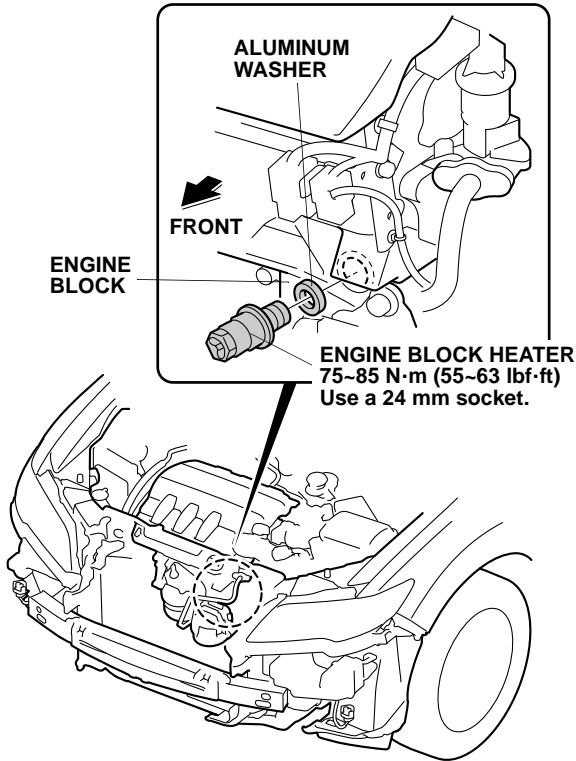

18. Plug the heater harness connector into the engine block heater.

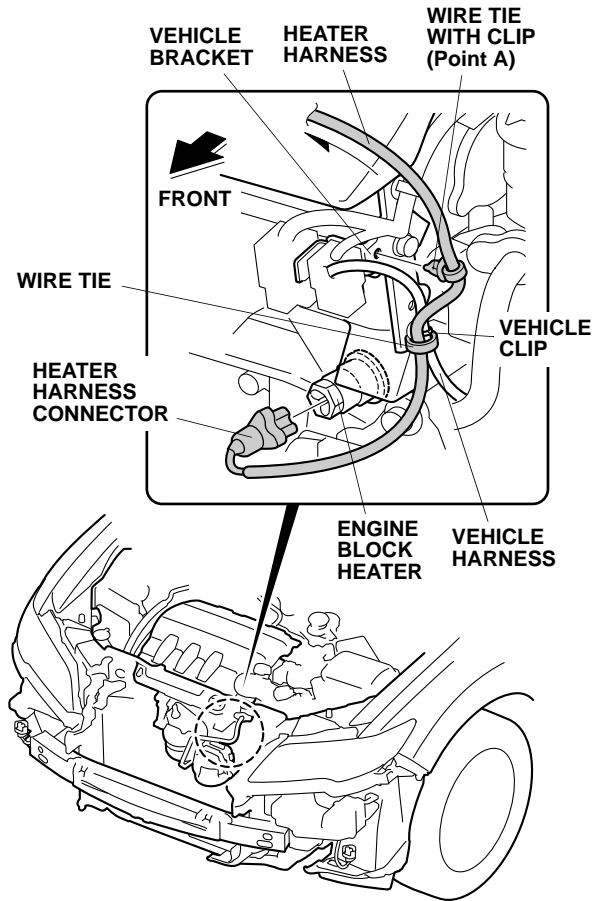

19. Route the heater harness in the direction shown, and secure the wire tie with clip (point A) to the vehicle bracket. Secure the heater harness to the vehicle harness with one wire tie.

20. Route the heater harness as shown, and secure it to the fan shroud rib with one wire tie (point B).

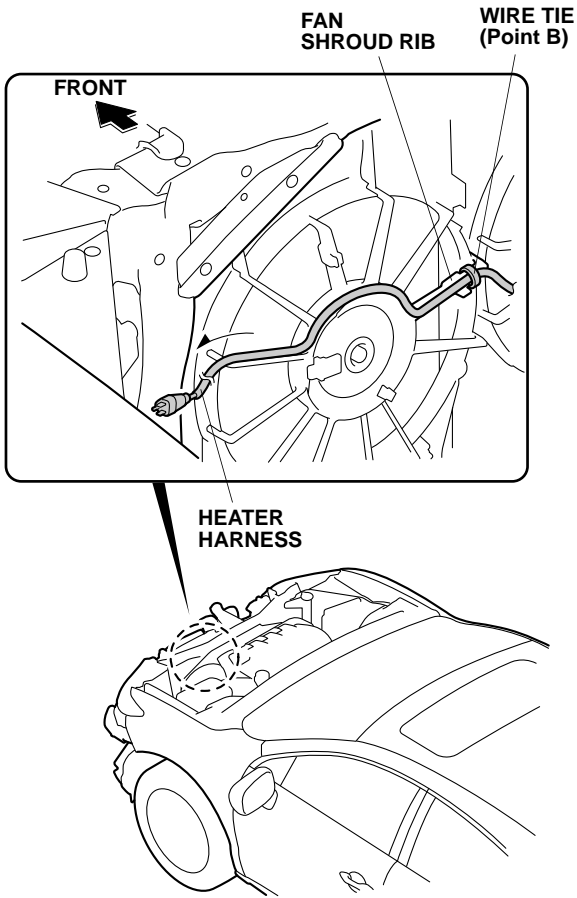

21. Continue routing the heater harness along the vehicle harness.

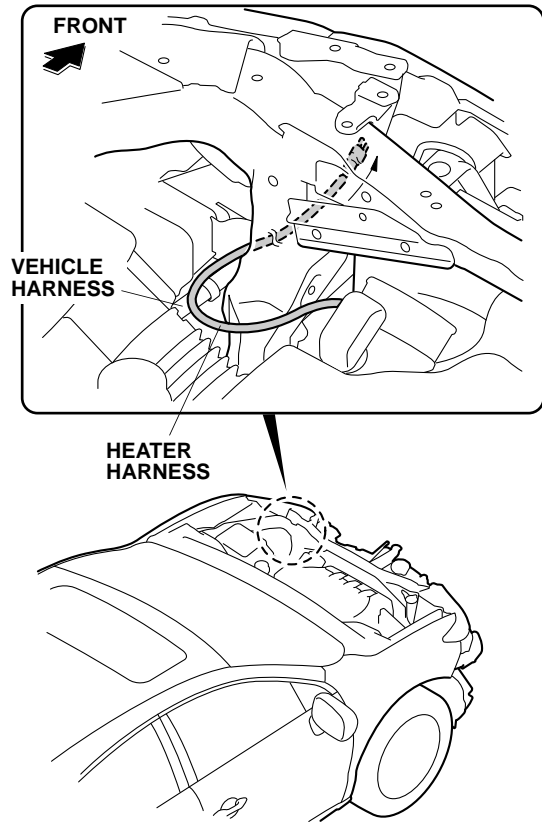

22. Route the heater harness under the left headlight, and secure it to the side duct with one black wire tie (point C).

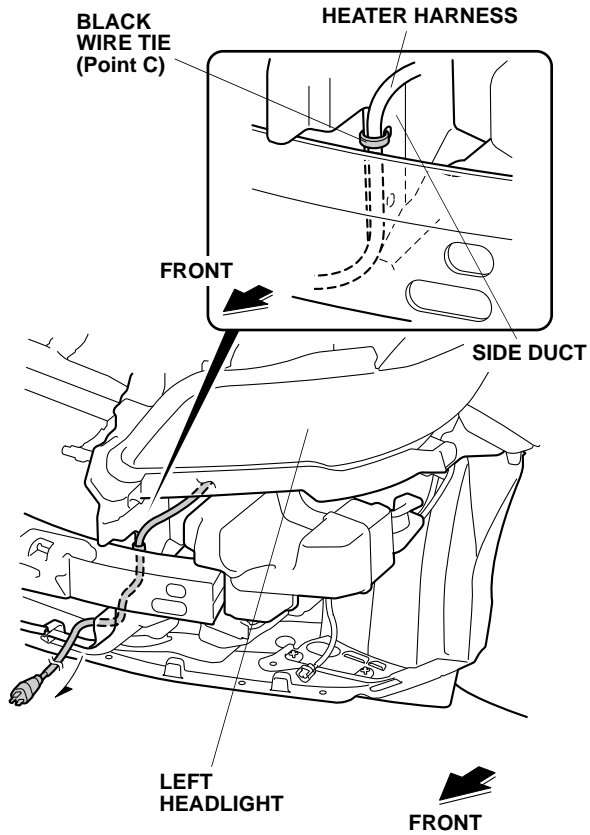

23. Route the heater harness along the engine under cover, and secure it to the engine under cover with one black wire tie (point D).

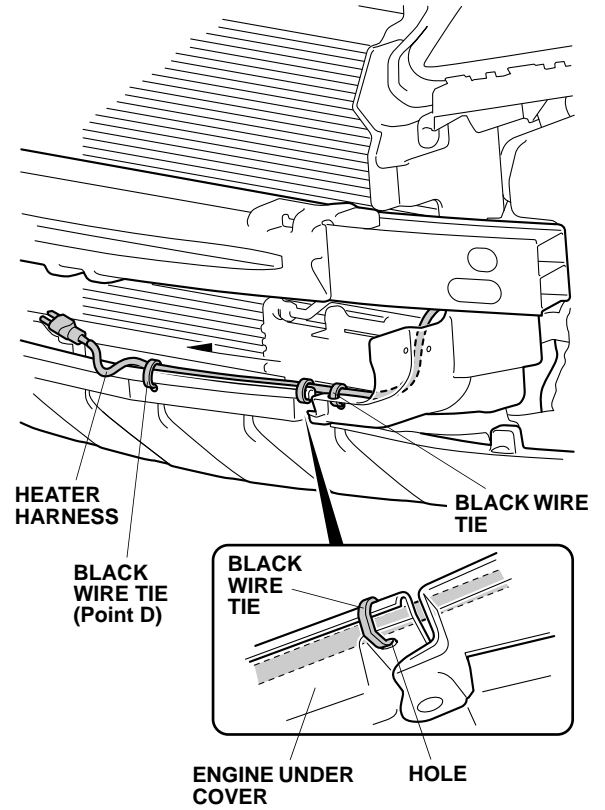

24. Secure the heater harness to the side duct and engine under cover with two black wire ties.

25. Secure the heater harness to the side duct with two black wire ties.

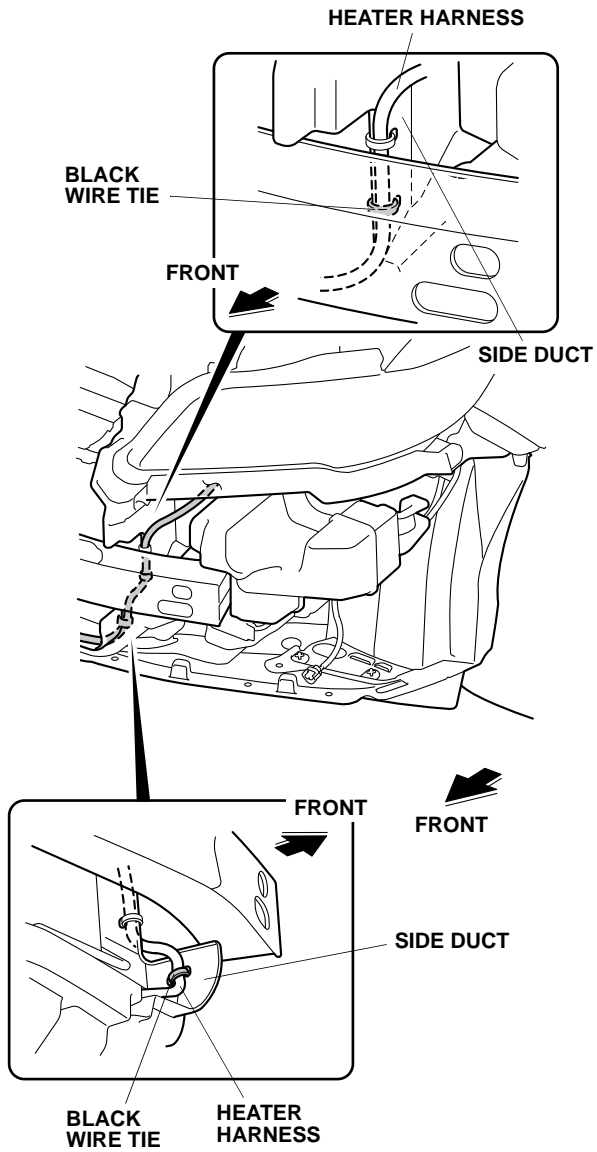

26. Secure the heater harness to the vehicle harness with one wire tie.

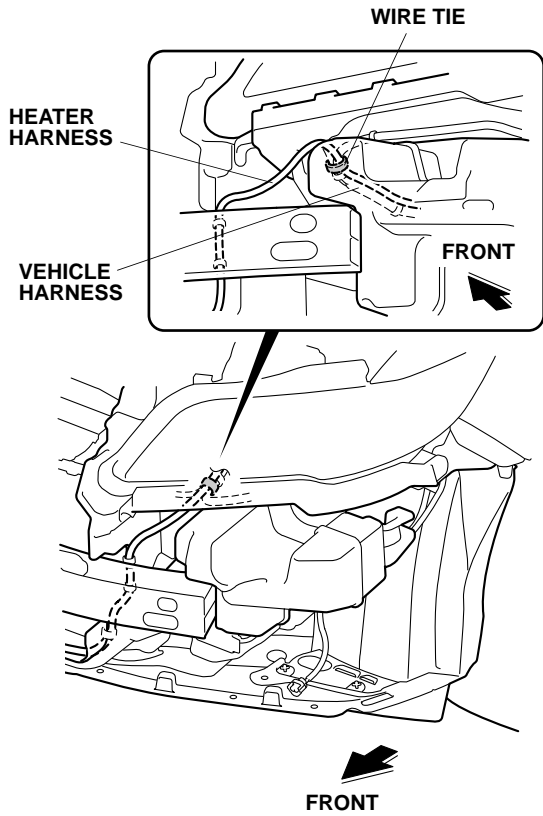

27. Secure the heater harness to the vehicle harness with one black wire tie.

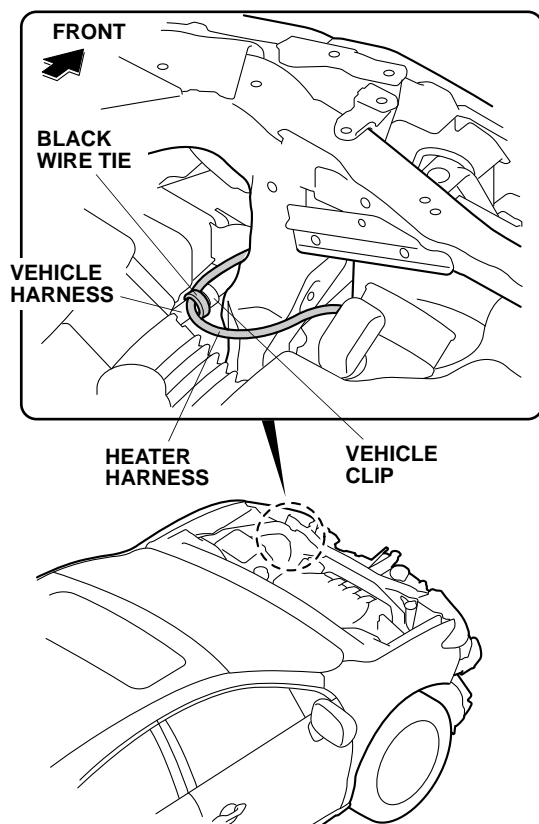

28. Secure the heater harness to the fan shroud ribs with five black wire ties.

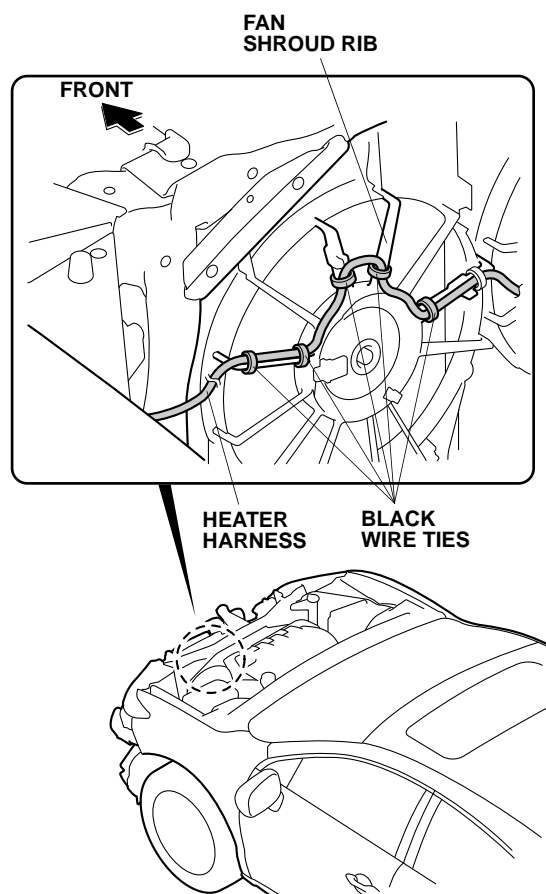

29. With the help of an assistant, route the heater harness through the front bumper opening, and reinstall the front bumper.

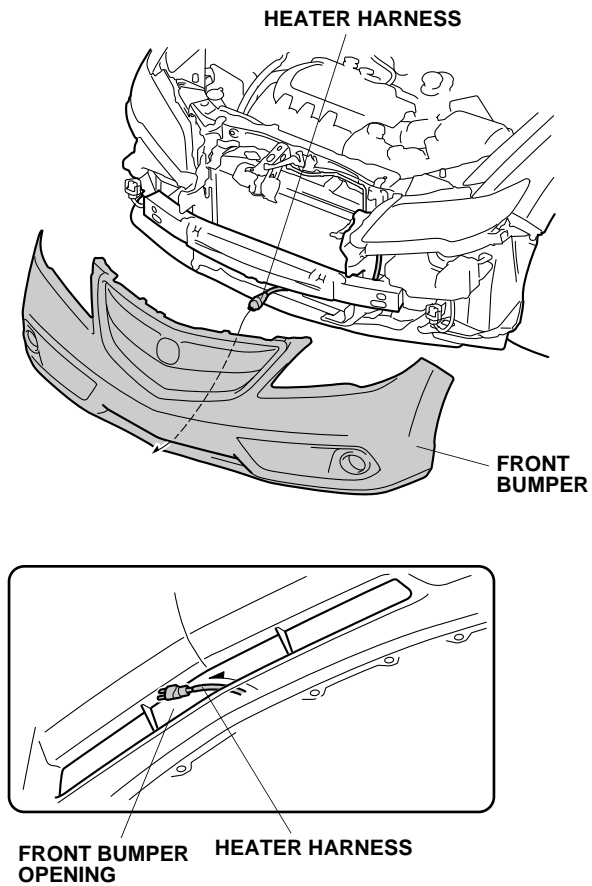

30. Install the protective cap to the front bumper as shown.

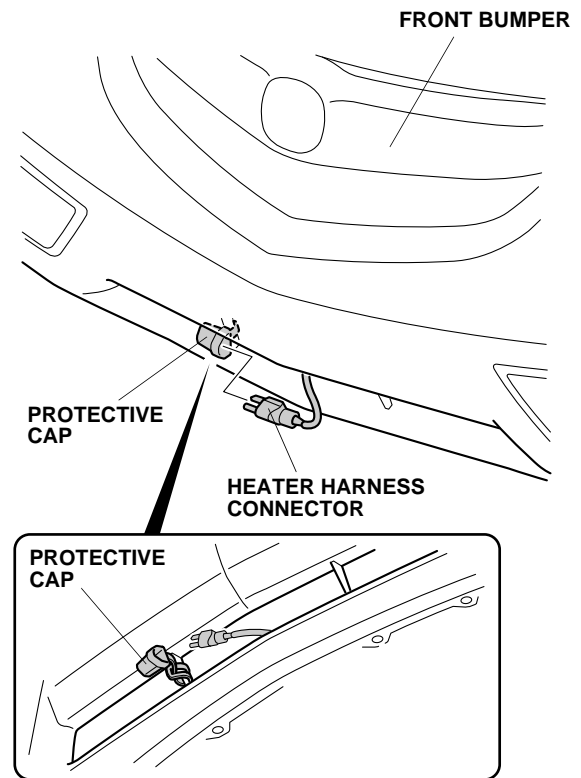

31. Install the heater harness connector into the protective cap.
32. Reinstall all removed parts, except for the radiator cap.
33. Fill the system with the recommended coolant. Follow the instructions in the service manual to fill the cooling system and check for leaks. Make sure there is no leak around the engine block heater.
34. Reinstall the radiator cap.
35. Check that the heater harness is routed properly and all connectors are plugged in.
36. Store the drain bolt (removed in step 16) in the glove box.
37. Reconnect the negative cable to the battery.
38. Press and hold the radio power button for two seconds to restore the radio and navi (if equipped) system functions.
39. Reset the clock.